

5261B-SR

**Wi-Fi Dual-band 2X2 11ac + Bluetooth 5.0
Combo Module Datasheet**



5261B-SR Module Datasheet

Office: 6 Floor, Building U6, Junxiang U8 Park,
Hangcheng Avenue, Bao'an District,
Shenzhen City, CHINA

Factory: No.8, Litong Road, Liuyang Economic & Technical
Development Zone, Changsha, Hunan, CHINA

TEL: +86-755-2955-8186

Website: www.fn-link.com

Customer Approval: _____ Company

Title

Signature

Date

Fn-Link

Revision History

Version	Date	Revision Content	Draft	Approved
1.0	2019/04/25	New version	Lgp	Lxy
1.1	2019/08/02	Update module photo	Lxy	Szs
1.2	2020/05/08	Update temperature info	Lxy	Szs
1.3	2020/06/17	Update material picture	Lxy	Szs
1.4	2021/03/27	Update reflow parameters	Lxy	Szs
1.5	2021/04/01	Update dimension diagram	Lxy	Szs

CONTENTS

1 Overview	1
1.1 Introduction	1
1.2 Features	1
1.3 General Specification	2
1.4 Recommended Operating Rating	3
※1.5 EEPROM Information	3
2 Wi-Fi RF Specification	4
2.1 2.4GHz RF Specification	4
2.2 5GHz RF Specification	6
3 Bluetooth Specification	9
3.1 Bluetooth Specification	9
4 Pin Assignments	10
4.1 Pin Outline	10
4.2 Pin Definition	10
5 Dimensions	13
5.1 Module Picture	13
5.2 Label Marking & Size 9x9mm	13
5.3 Module Physical Dimensions	14
5.4 Layout Recommendation	15
6 Host Interface Timing Diagram	16
6.1 SDIO Pin Description	16
6.2 SDIO Default Mode Timing Diagram	17
6.3 SDIO High Speed Mode Timing Diagram	18
6.4 SDIO Bus Timing Specifications in SDR Modes	19
6.5 SDIO Bus Timing Specifications in DDR50 Mode	21
7 Reference Design	23
8 Ordering Information	24
9 The Key Material List	25
10 Recommended Reflow Profile	26
11 Package Information	27
11.1 Reel	27
11.2 Carrier Tape Detail	27
11.3 Packaging Detail	28
11.4 Moisture sensitivity	28

1 Overview

1.1 Introduction

Fn-Link Technology would like to announce a low-cost and low-power consumption module which has all of the Wi-Fi and Bluetooth functionalities. The highly integrated module makes the possibilities of web browsing, VoIP, Bluetooth headsets applications. With seamless roaming capabilities and advanced security, also could interact with different vendors' 802.11a/b/g/n/ac 2x2 Access Points in the wireless LAN.

5261B-SR module complies with IEEE 802.11 a/b/g/n/ac 2x2 dual-band Wi-Fi subsystem and a Bluetooth subsystem. The Wi-Fi subsystem contains the 802.11 a/b/g/n/ac radio, baseband, and MAC that are designed to meet both the low power and high throughput application.

5261B-SR has a 32-bit RISC MCU that handles Wi-Fi and Bluetooth tasks, and an ARM Cortex-R4 MCU that could offload data frame processing in Wi-Fi host driver. The Bluetooth subsystem contains the Bluetooth radio, baseband, link controller. It also uses the 32-bit RISC MCU for the Bluetooth protocols.

This compact module is a total solution for a combination of Wi-Fi and Bluetooth V5.0 technologies. The module is specifically developed for all portable devices.

1.2 Features

- Integrate high efficiency power management unit with single 3.3V power supply input
- SDIO device fully compliant to SDIO 3.0 specification
- Programmable and multiplexed GPIO pins
- IEEE 802.11 a/b/g/n/ac compliant
- Support 20MHz, 40MHz, 80Mhz bandwidth in 2.4GHz band 5GHz band
- Dual-band 2T2R mode, data rate up to 450Mbps with SDIO 3.0
- Support MU-MIMO RX and DBDC (dual band dual concurrent)
- Support STBC, LDPC, TX Beamformer and RX Beamformee
- Greenfield, mixed mode, legacy modes support
- IEEE 802.11 d/e/h/i/j/k/mc/r/v/w support
- Security support for WFA WPA/WPA2 personal, WPS 2.0, WAPI
- QoS support of WFA WMM, WMM PS
- Support Bluetooth 5.0

Block Diagram:

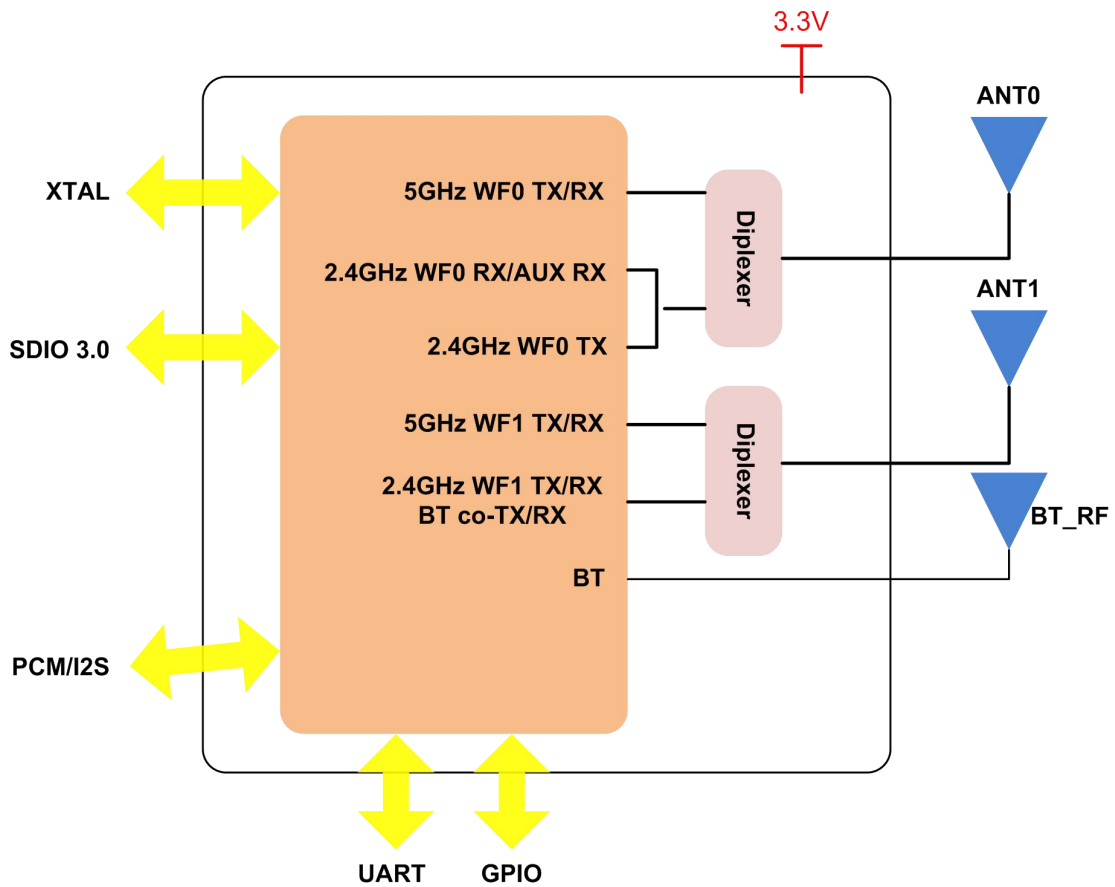

1.3 General Specification

Model Name	5261B-SR
Product Description	Support Wi-Fi/Bluetooth functionalities
Dimension	L x W x H: 15 x 13 x 1.65mm
OS Support	Linux, Android
Wi-Fi Interface	Support SDIO V3.0
BT Interface	Support SDIO V3.0
Operating temperature	-10°C ¹ to 70°C
Storage temperature	-40°C to 125°C
RoHS	All hardware components are fully compliant with EU RoHS directive

1. operating temperature actually passed at -20° C.

1.4 Recommended Operating Rating

The digital IO supports VDD33 or VDD18 application

		Min.	Typ.	Max.	Unit
Operating Temperature		-10	25	70	deg.C
VDD33		2.97	3.3	3.63	V
VDD18		1.7	1.8	1.9	V
VESD(HBM)	VBAT	-	-	2K	V
	ANT0	-	-	2K	V
	ANT1	-	-	2K	V
	BT_RF	-	-	2K	V

※1.5 EEPROM Information

WI-FI

Vendor ID	-
Device ID	-

BT

Vendor ID	-
Product ID	-

2 Wi-Fi RF Specification

2.1 2.4GHz RF Specification

Feature	Description			
WLAN Standard	IEEE 802.11 b/g/n Wi-Fi compliant			
Frequency Range	2.400 GHz ~ 2.497 GHz (2.4 GHz ISM Band)			
Number of Channels	2.4GHz: Ch1 ~ Ch14			
Spectrum Mask	Compliance with IEEE standard			
Freq. Tolerance	-20/-20/-20	-	20/20/20	ppm
Test Items	Typical Value			EVM
Output Power	802.11b /11Mbps: 17dBm ± 1.5 dB			EVM ≤ -9dB
	802.11g /54Mbps: 15dBm ± 1.5 dB			EVM ≤ -25dB
	802.11n /MCS7: 14dBm ± 1.5 dB			EVM ≤ -28dB
Test Items	Test Value			Standard Value
SISO Receive Sensitivity (11b,20MHz) @8% PER	- 1Mbps	PER @ -92 dBm	≤-83	
	- 2Mbps	PER @ -90 dBm	≤-80	
	- 5.5Mbps	PER @ -87 dBm	≤-79	
	- 11Mbps	PER @ -85 dBm	≤-76	
SISO Receive Sensitivity (11g,20MHz) @10% PER	- 6Mbps	PER @ -89 dBm	≤-85	
	- 9Mbps	PER @ -88 dBm	≤-84	
	- 12Mbps	PER @ -87 dBm	≤-82	
	- 18Mbps	PER @ -84 dBm	≤-80	
	- 24Mbps	PER @ -81 dBm	≤-77	
	- 36Mbps	PER @ -78 dBm	≤-73	
	- 48Mbps	PER @ -73 dBm	≤-69	
	- 54Mbps	PER @ -71 dBm	≤-68	
SISO Receive Sensitivity (11n,20MHz) @10% PER	- MCS=0	PER @ -89 dBm	≤-85	
	- MCS=1	PER @ -86 dBm	≤-82	
	- MCS=2	PER @ -84 dBm	≤-80	
	- MCS=3	PER @ -80 dBm	≤-77	
	- MCS=4	PER @ -77 dBm	≤-73	
	- MCS=5	PER @ -72 dBm	≤-69	
	- MCS=6	PER @ -71 dBm	≤-68	
	- MCS=7	PER @ -69 dBm	≤-67	
SISO Receive Sensitivity	- MCS=0	PER @ -88 dBm	≤-82	

(11n ,40MHz) @10% PER	- MCS=1	PER @ -85 dBm	≤-79
	- MCS=2	PER @ -83 dBm	≤-77
	- MCS=3	PER @ -79 dBm	≤-74
	- MCS=4	PER @ -76 dBm	≤-70
	- MCS=5	PER @ -72 dBm	≤-66
	- MCS=6	PER @ -70 dBm	≤-65
	- MCS=7	PER @ -69 dBm	≤-64
Maximum Input Level	802.11b: -10 dBm		
	802.11g/n: -20 dBm		
Antenna Reference	Small antennas with 0~2 dBi peak gain		

2.2 5GHz RF Specification

Conditions : VBAT=3.3V ; VDDIO=3.3V ; Temp:25°C

Feature	Description	
WLAN Standard	IEEE 802.11a/n/ac, Wi-Fi compliant	
Frequency Range	4.900 GHz ~ 5.845 GHz (5.0 GHz ISM Band)	
Number of Channels	5.0GHz: Please see the table ¹	
Test Items	Typical Value	EVM
Output Power	802.11a /54Mbps: 15±1.5 dBm	EVM ≤ -25dB
	802.11n /MCS7: 14±1.5 dBm	EVM ≤ -28dB
	802.11ac /MCS9: 13± 1.5 dBm	EVM ≤ -32dB
Test Items	Test Value	Standard Value
SISO Receive Sensitivity (11a,20MHz) @10% PER	- 6Mbps PER @ -88 dBm	≤-85
	- 9Mbps PER @ -87 dBm	≤-84
	- 12Mbps PER @ -86 dBm	≤-82
	- 18Mbps PER @ -83 dBm	≤-80
	- 24Mbps PER @ -80 dBm	≤-77
	- 36Mbps PER @ -77 dBm	≤-73
	- 48Mbps PER @ -72 dBm	≤-69
	- 54Mbps PER @ -70 dBm	≤-68
SISO Receive Sensitivity (11n,20MHz) @10% PER	- MCS=0 PER @ -88 dBm	≤-85
	- MCS=1 PER @ -85 dBm	≤-82
	- MCS=2 PER @ -83 dBm	≤-80
	- MCS=3 PER @ -80 dBm	≤-77
	- MCS=4 PER @ -76 dBm	≤-73
	- MCS=5 PER @ -71 dBm	≤-69
	- MCS=6 PER @ -70 dBm	≤-68
	- MCS=7 PER @ -68 dBm	≤-67
SISO Receive Sensitivity (11n,40MHz) @10% PER	- MCS=0 PER @ -85 dBm	≤-82
	- MCS=1 PER @ -82 dBm	≤-79
	- MCS=2 PER @ -80 dBm	≤-77
	- MCS=3 PER @ -77 dBm	≤-74
	- MCS=4 PER @ -73 dBm	≤-70
	- MCS=5 PER @ -69 dBm	≤-66
	- MCS=6 PER @ -67 dBm	≤-65
	- MCS=7 PER @ -66 dBm	≤-64
SISO Receive Sensitivity	- MCS=0, NSS1 PER @ -86 dBm	≤-82

(11ac,20MHz) @10% PER	- MCS=1, NSS1 PER @ -84 dBm	≤-80
	- MCS=2, NSS1 PER @ -82 dBm	≤-77
	- MCS=3, NSS1 PER @ -79 dBm	≤-73
	- MCS=4, NSS1 PER @ -75 dBm	≤-69
	- MCS=5, NSS1 PER @ -70 dBm	≤-68
	- MCS=6, NSS1 PER @ -69 dBm	≤-67
	- MCS=7, NSS1 PER @ -68 dBm	≤-62
	- MCS=8, NSS1 PER @ -64 dBm	≤-60
SISO Receive Sensitivity (11ac,40MHz) @10% PER	- MCS=0, NSS1 PER @ -84 dBm	≤-79
	- MCS=1, NSS1 PER @ -81 dBm	≤-77
	- MCS=2, NSS1 PER @ -79 dBm	≤-74
	- MCS=3, NSS1 PER @ -76 dBm	≤-70
	- MCS=4, NSS1 PER @ -73 dBm	≤-66
	- MCS=5, NSS1 PER @ -68 dBm	≤-65
	- MCS=6, NSS1 PER @ -67 dBm	≤-64
	- MCS=7, NSS1 PER @ -66 dBm	≤-59
	- MCS=8, NSS1 PER @ -61 dBm	≤-57
	- MCS=9, NSS1 PER @ -58 dBm	≤-55
SISO Receive Sensitivity (11ac,80MHz) @10% PER	- MCS=0, NSS1 PER @ -81 dBm	≤-79
	- MCS=1, NSS1 PER @ -78 dBm	≤-76
	- MCS=2, NSS1 PER @ -76 dBm	≤-74
	- MCS=3, NSS1 PER @ -72 dBm	≤-71
	- MCS=4, NSS1 PER @ -69 dBm	≤-67
	- MCS=5, NSS1 PER @ -66 dBm	≤-63
	- MCS=6, NSS1 PER @ -64 dBm	≤-62
	- MCS=7, NSS1 PER @ -62 dBm	≤-61
	- MCS=8, NSS1 PER @ -58 dBm	≤-56
	- MCS=9, NSS1 PER @ -56 dBm	≤-54
Maximum Input Level	802.11a/n : -30 dBm	
Antenna Reference	Small antennas with 0~2 dBi peak gain	

15GHz(20MHz) Channel table

Band range	Operating Channel Numbers	Channel center frequencies (MHz)
5180MHz~5240MHz	36	5180
	40	5200
	44	5220
	48	5240

5260MHz~5320MHz	52	5260
	56	5280
	60	5300
	64	5320
5550MHz~5700MHz	100	5500
	104	5520
	108	5540
	112	5560
	116	5580
	120	5600
	124	5620
	128	5640
	132	5660
	136	5680
	140	5700
5745MHz~5825MHz	149	5745
	153	5765
	157	5785
	161	5805
	165	5825

3 Bluetooth Specification

3.1 Bluetooth Specification

Feature	Description		
General Specification			
Bluetooth Standard	Bluetooth V5.0		
Host Interface	SDIO		
Antenna Reference	Small antennas with 0~2 dBi peak gain		
Frequency Band	2400 MHz ~ 2483.5 MHz		
Number of Channels	79 channels		
Modulation	GFSK, $\pi/4$ -DQPSK, 8DPSK		
RF Specification			
	Min.	Typical.	Max.
Output Power (Class 1)	0	6 dBm	12
Sensitivity @ BER=0.1% for GFSK (1Mbps)		-89 dBm	
Sensitivity @ BER=0.01% for $\pi/4$ -DQPSK (2Mbps)		-85 dBm	
Sensitivity @ BER=0.01% for 8DPSK (3Mbps)		-83 dBm	
Maximum Input Level	GFSK (1Mbps): -20dBm		
	$\pi/4$ -DQPSK (2Mbps): -20dBm		
	8DPSK (3Mbps) : -20dBm		

4 Pin Assignments

4.1 Pin Outline

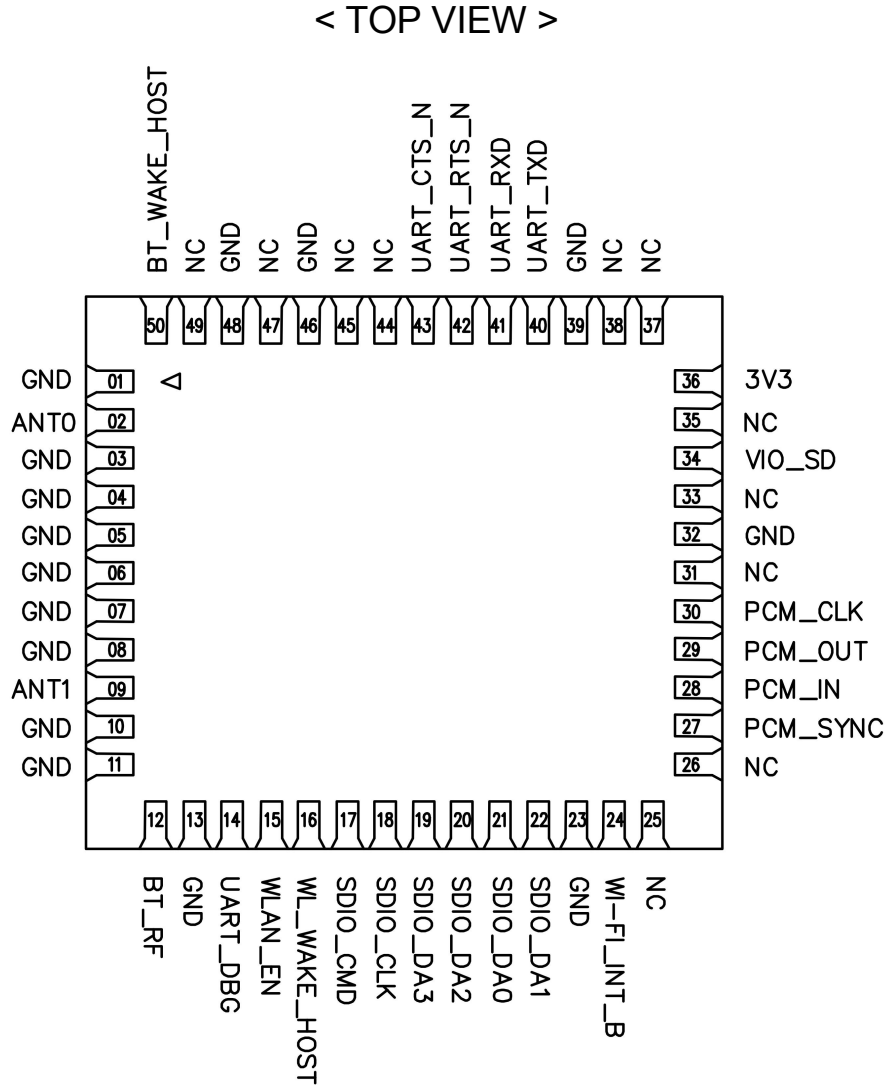

4.2 Pin Definition

The section describes the pin functionality of 5261B-SR chip.

NO	Name	Type	Description	Voltage
1	GND	-	Ground connections	
2	ANT0	I/O	RF I/O port chain0	
3	GND	-	Ground connections	
4	GND	-	Ground connections	
5	GND	-	Ground connections	
6	GND	-	Ground connections	
7	GND	-	Ground connections	



8	GND	-	Ground connections	
9	ANT1	I/O	RF I/O port chain1	
10	GND	-	Ground connections	
11	GND	-	Ground connections	
12	BT_ANT	I/O	Bluetooth RF	
13	GND	-	Ground connections	
14	UART_DBG	I/O	UART debug, If no used please NC	
15	WLAN_EN	I	Wi-Fi device reset pin Default ON: pull high; RST: pull low	VDDIO
16	WL_WAKE_HOST	O	WLAN to wake-up HOST	VDDIO
17	SDIO_CMD	I/O	SDIO command line	
18	SDIO_CLK	I/O	SDIO clock line	
19	SDIO_DA3	I/O	SDIO data line 3	
20	SDIO_DA2	I/O	SDIO data line 2	
21	SDIO_DA0	I/O	SDIO data line 0	
22	SDIO_DA1	I/O	SDIO data line 1	
23	GND	-	Ground connections	
24	WI-FI_INT_B	O	Wi-Fi host interrupt, If no used please NC	VDDIO
25	NC	-	Floating (Don't connected to ground)	
26	NC	-	Floating (Don't connected to ground)	
27	PCM_SYNC	I/O	PCM interface sync	VDDIO
28	PCM_IN	I/O	PCM interface input data	VDDIO
29	PCM_OUT	O	PCM interface output data	VDDIO
30	PCM_CLK	O	PCM interface clock	VDDIO
31	NC	-	Floating (Don't connected to ground)	
32	GND	-	Ground connections	
33	NC	-	Floating (Don't connected to ground)	
34	VIO_SD	P	I/O Voltage supply input	1.8V or 3.3V
35	NC	-	Floating (Don't connected to ground)	
36	3V3	P	Main power voltage source input 3.3V	3.3V
37	NC	-	Floating (Don't connected to ground)	
38	NC	-	Floating (Don't connected to ground)	
39	GND	-	Ground connections	
40	UART_TXD	O	UART Tx, If no used please NC	
41	UART_RXD	I	UART Rx, If no used please NC	
42	UART_RTS_N	I	UART RTS, If no used please NC	

43	UART_CTS_N	O	UART CTS, If no used please NC	
44	NC	-	Floating (Don't connected to ground)	
45	NC	-	Floating (Don't connected to ground)	
46	GND	-	Ground connections	
47	NC	-	Floating (Don't connected to ground)	
48	GND	-	Ground connections	
49	NC	-	Floating (Don't connected to ground)	
50	BT_WAKE_HOST	O	Bluetooth device to wake-up HOST	VDDIO

P: POWER I:INPUT O:OUTPUT VDDIO:1.8V or 3.3V

5 Dimensions

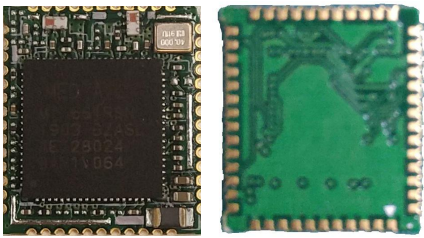
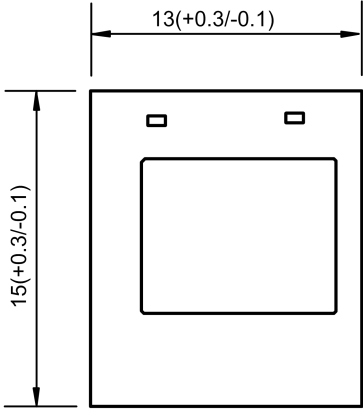
5.1 Module Picture

<p>L x W: 15 x 13 (+0.3/-0.1) mm</p> 	
<p>H: 1.65 (±0.2) mm</p>	
<p>Weight</p>	<p>0.56g</p>

5.2 Label Marking & Size

N/A

5.3 Module Physical Dimensions

(Unit: mm)四边角位置分板会有余留

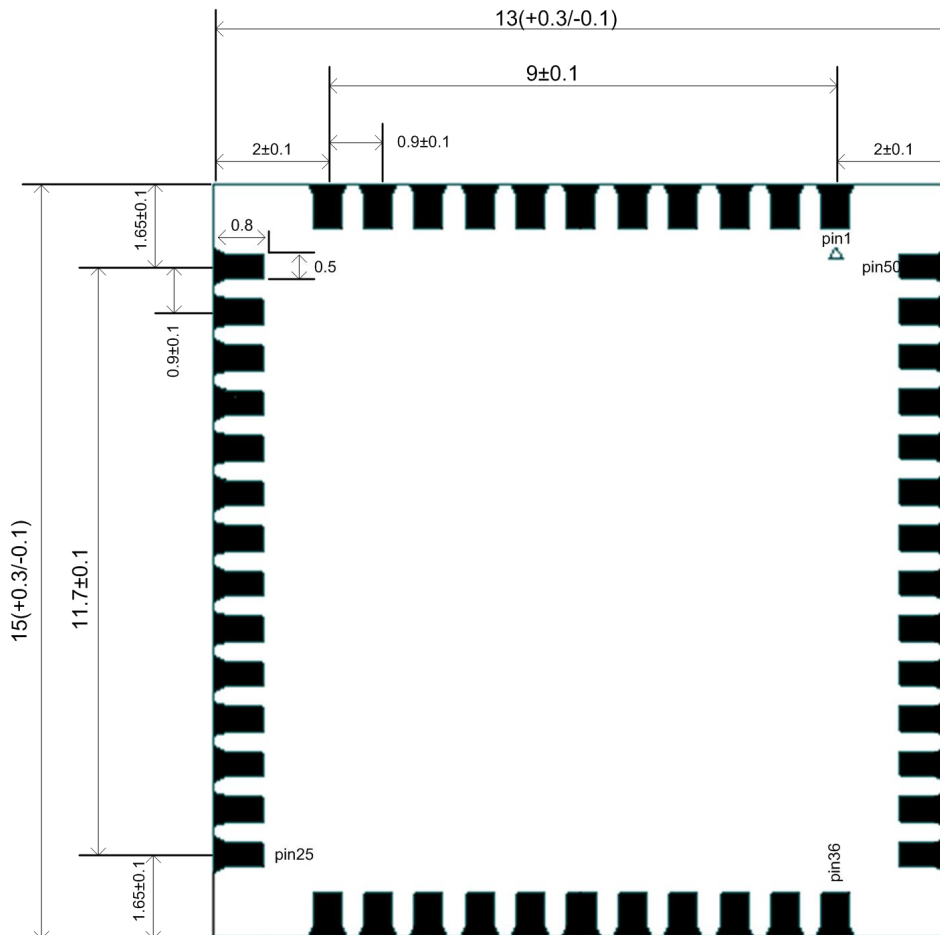

< TOP VIEW >

5.4 Layout Recommendation

(Unit: mm)

< TOP VIEW >

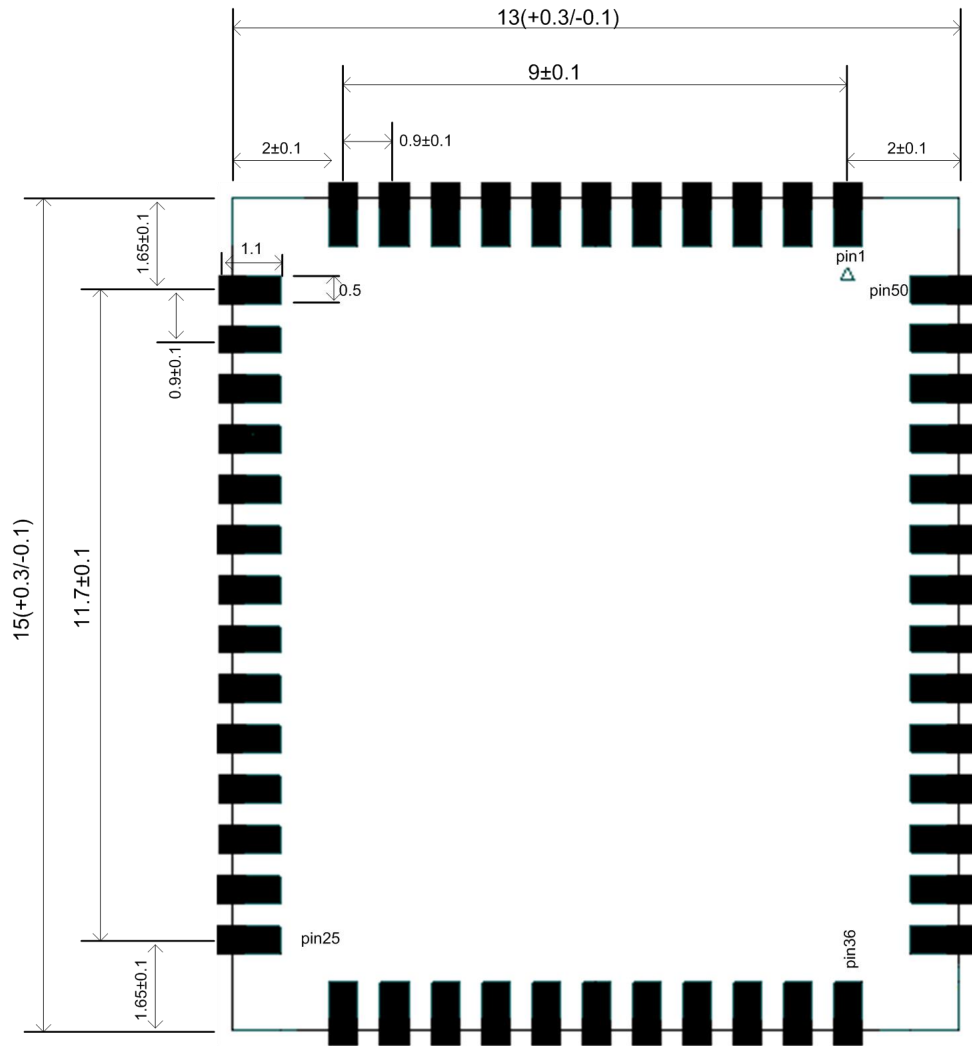

6 Host Interface Timing Diagram

6.1 SDIO Pin Description

The module supports SDIO version 3.0 for all 1.8V 4-bit UHSI speeds: SDR50(100 Mbps), SDR104(208MHz) and DDR50(50MHz, dual rates) in addition to the 3.3V default speed(25MHz) and high speed (50 MHz). It has the ability to stop the SDIO clock and map the interrupt signal into a GPIO pin.

SDIO Pin Description

SD 4-Bit Mode	
DATA0	Data Line 0
DATA1	Data Line 1 or Interrupt
DATA2	Data Line 2 or Read Wait
DATA3	Data Line 3
CLK	Clock
CMD	Command Line

6.2 SDIO Default Mode Timing Diagram

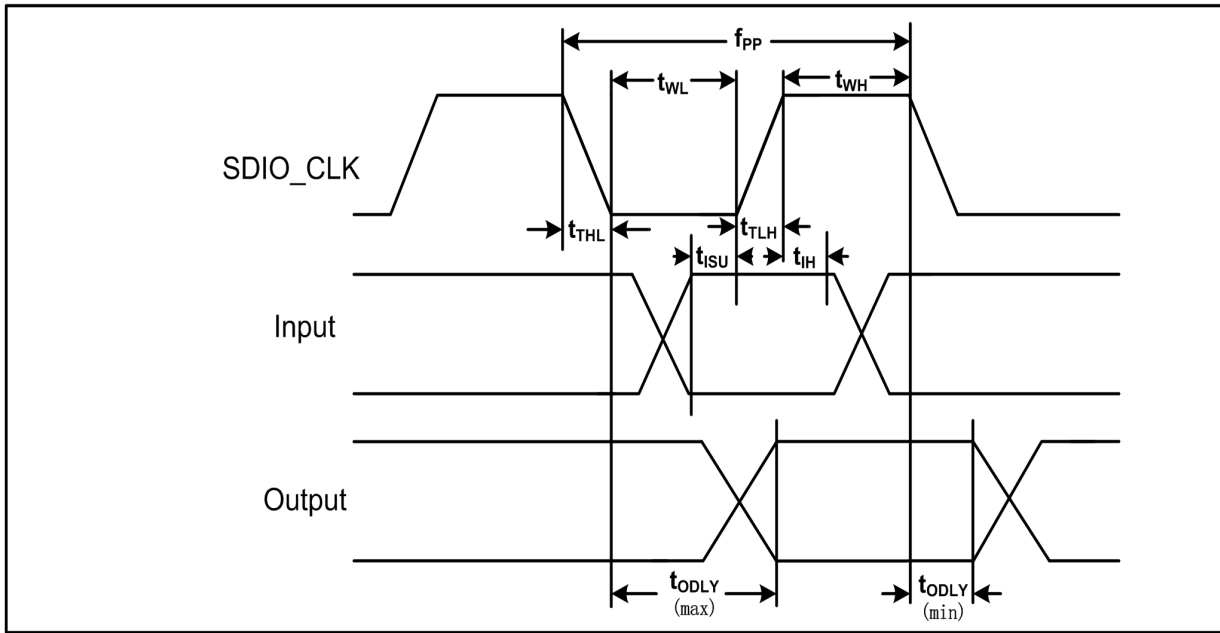

Parameter	Symbol	Minimum	Typical	Maximum	Unit
SDIO CLK(All values are referred to minimum VIH and maximum VIL^b)					
Frequency - Data Transfer mode	fPP	0	-	25	MHz
Frequency - Identification mode	fOD	0	-	400	kHz
Clock low time	tWL	10	-	-	ns
Clock high time	tWH	10	-	-	ns
Clock rise time	tTLH	-	-	10	ns
Clock low time	tTHL	-	-	10	ns
Inputs:CMD, DAT (referenced to CLK)					
Input setup time	tISU	5	-	-	ns
Input hold time	tIH	5	-	-	ns
Outputs:CMD, DAT (referenced to CLK)					
Output delay time - Data Transfer mode	tODLY	0	-	14	ns
Output delay time - Identification mode	tODLY	0	-	50	ns

- Timing is based on $CL \leq 40$ pF load on CMD and Data.
- Min (Vih) = $0.7 \times VDDIO$ and max (Vil) = $0.2 \times VDDIO$.

6.3 SDIO High Speed Mode Timing Diagram

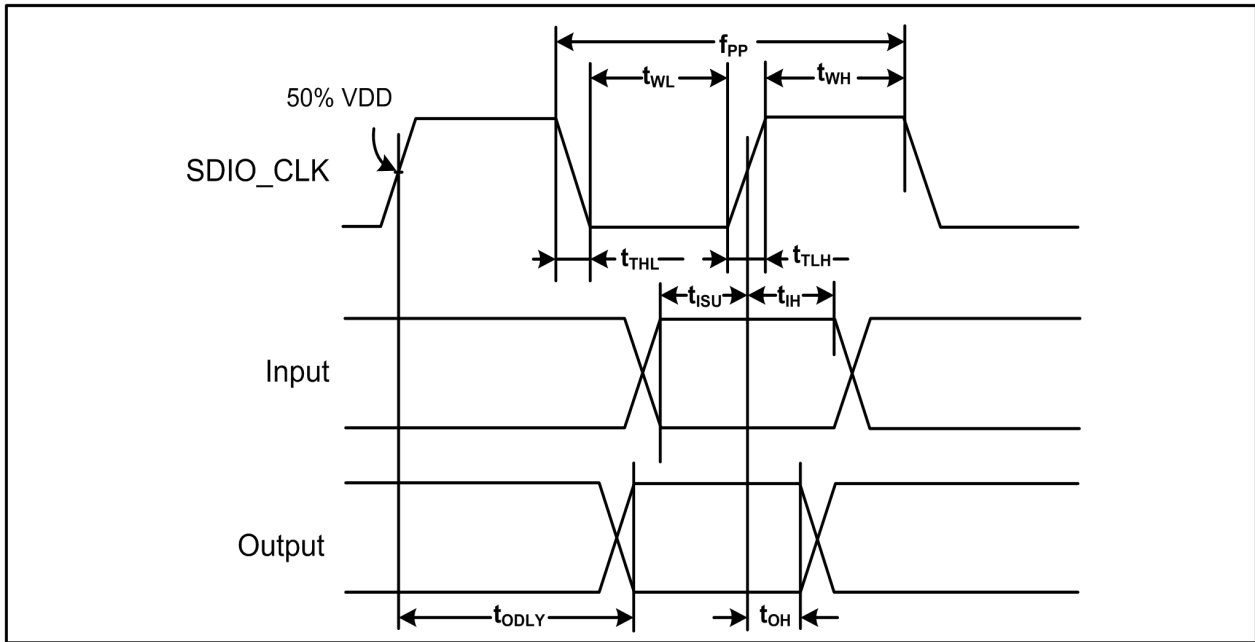

Parameter	Symbol	Minimum	Typical	Maximum	Unit
SDIO CLK (all values are referred to minimum VIH and maximum VIL^b)					
Frequency - Data Transfer mode	f _{PP}	0	-	50	MHz
Frequency - Identification mode	f _{OD}	0	-	400	kHz
Clock low time	t _{WL}	7	-	-	ns
Clock high time	t _{WH}	7	-	-	ns
Clock rise time	t _{TLH}	-	-	3	ns
Clock low time	t _{THL}	-	-	3	ns
Inputs:CMD, DAT (referenced to CLK)					
Input setup time	t _{ISU}	6	-	-	ns
Input hold time	t _{IH}	2	-	-	ns
Outputs:CMD, DAT (referenced to CLK)					
Output delay time - Data Transfer mode	t _{ODLY}	-	-	14	ns
Output delay time - Identification mode	t _{ODLY}	2.5	-	-	ns
Total system capacitance (each line)	CL	-	-	40	pF

- a. Timing is based on CL ≤ 40 pF load on CMD and Data.
- b. Min (V_{ih}) = 0.7 × VDDIO and max(V_{il}) = 0.2 × VDDIO.

6.4 SDIO Bus Timing Specifications in SDR Modes

Clock timing (SDR Modes)

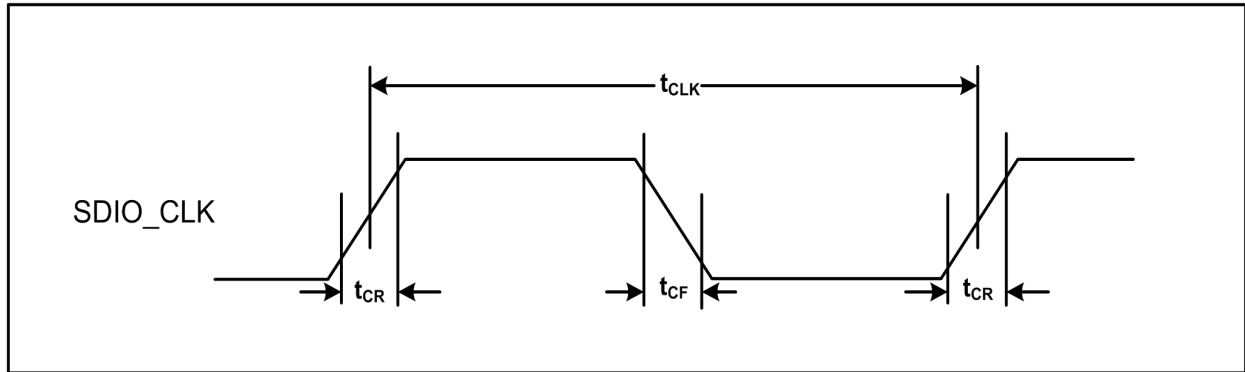

Parameter	Symbol	Minimum	Maximum	Unit	Comments
-	t_{CLK}	40	-	ns	SDR12 mode
-		20	-	ns	SDR25 mode
-		10	-	ns	SDR50 mode
-		4.8	-	ns	SDR104 mode
-	t_{CR}, t_{CF}	-	$0.2 \times t_{CLK}$	ns	$t_{CR}, t_{CF} < 2.00$ ns (max)@100 MHz, $C_{CARD} = 10$ pF $t_{CR}, t_{CF} < 0.96$ ns (max)@208 MHz, $C_{CARD} = 10$ pF
Clock duty	-	30	70	%	-

Card Input timing (SDR Modes)

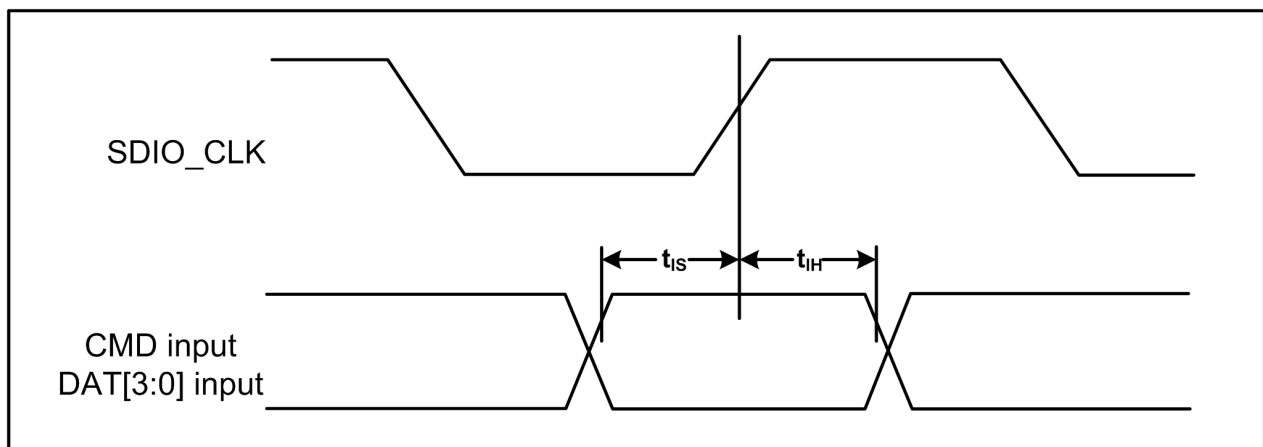

Symbol	Minimum	Maximum	Unit	Comments
SDR104 Mode				
t_{IS}	1.70 ^a	-	ns	$C_{CARD} = 10\text{pF}$, $V_{CT} = 0.975\text{V}$
t_{IH}	0.80	-	ns	$C_{CARD} = 5\text{pF}$, $V_{CT} = 0.975\text{V}$
SDR50 Mode				
t_{IS}	3.00	-	ns	$C_{CARD} = 10\text{pF}$, $V_{CT} = 0.975\text{V}$
t_{IH}	0.80	-	ns	$C_{CARD} = 5\text{pF}$, $V_{CT} = 0.975\text{V}$

a. SDIO 3.0 specification value is 1.40 ns.

Card output timing (SDR Modes up to 100MHz)

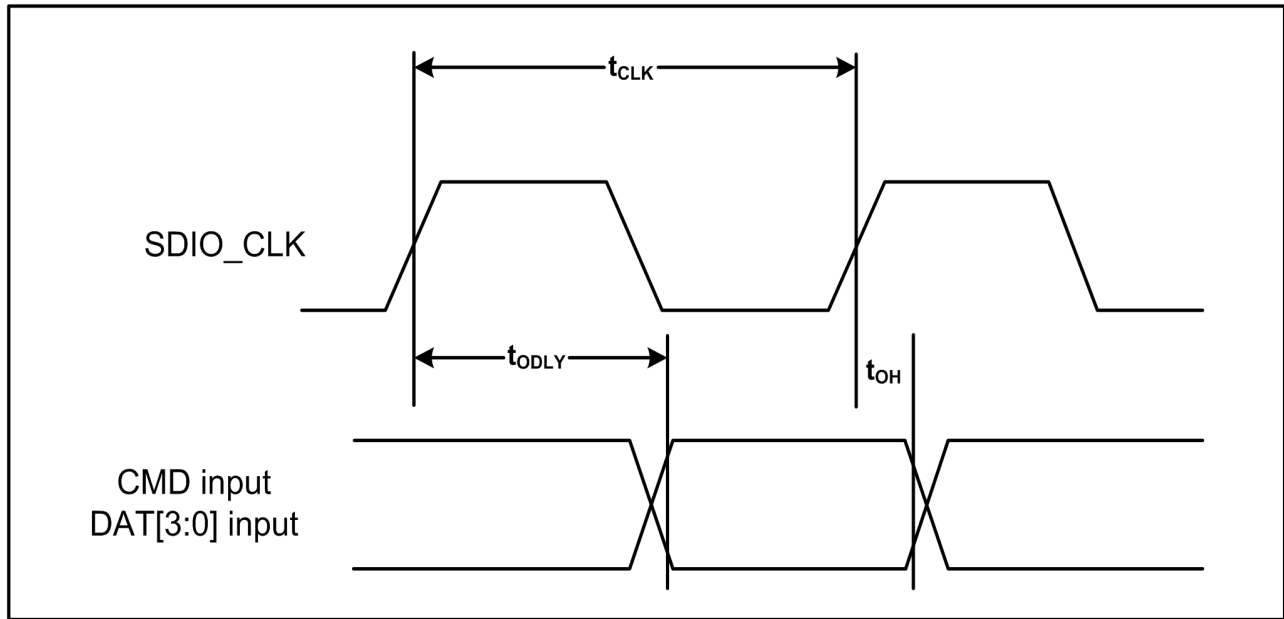

Symbol	Minimum	Maximum	Unit	Comments
t_{ODLY}	-	7.85 ^a	ns	$t_{CLK} \geq 10\text{ ns}$ $C_L = 30\text{ pF}$ using driver type B for SDR50
t_{ODLY}	-	14.0	ns	$t_{CLK} \geq 20\text{ ns}$ $C_L = 40\text{ pF}$ using for SDR12, SDR25
t_{OH}	1.5	-	ns	Hold time at the $t_{ODLY}(\text{min})$ $C_L = 15\text{ pF}$

a. SDIO 3.0 specification value is 7.5 ns.

Card output timing (SDR Modes 100MHz to 208MHz)

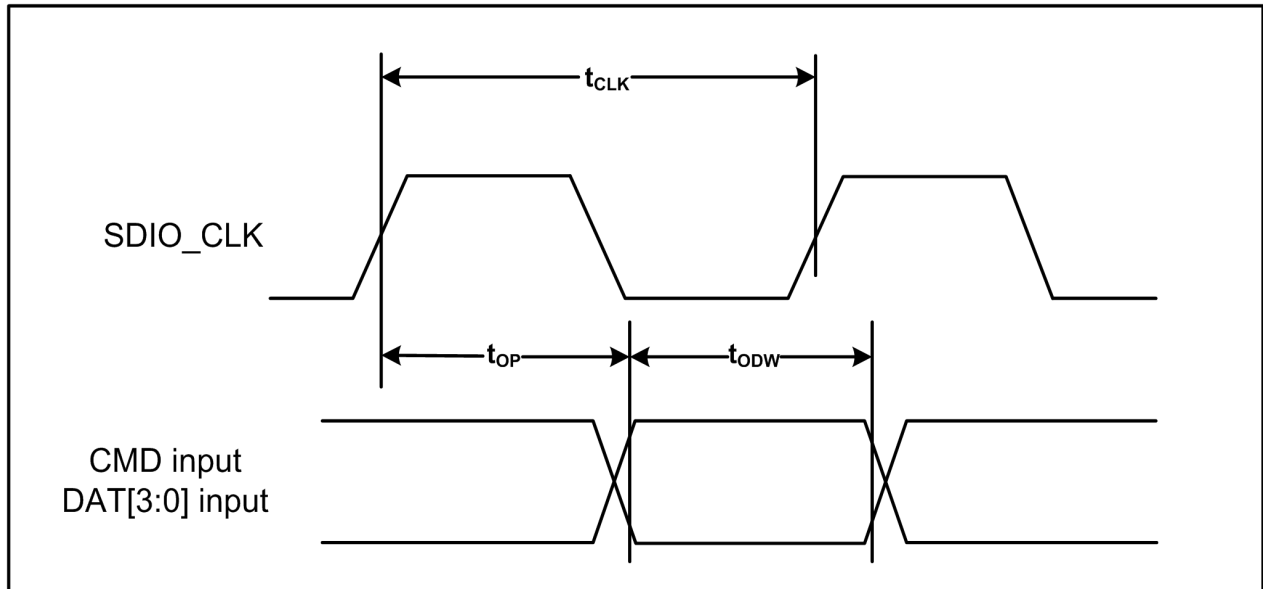

Symbol	Minimum	Maximum	Unit	Comments
t_{OP}	0	2	UI	Card output phase
Δt_{OP}	-350	+1550	ps	Delay variation due to temp change after tuning
t_{ODW}	0.6	-	UI	$t_{ODW} = 2.88 \text{ ns @ } 208 \text{ MHz}$

- $\Delta t_{OP} = +1550 \text{ ps}$ for junction temperature of $\Delta t_{OP} = 90$ degrees during operation
- $\Delta t_{OP} = -350 \text{ ps}$ for junction temperature of $\Delta t_{OP} = -20$ degrees during operation
- $\Delta t_{OP} = +2600 \text{ ps}$ for junction temperature of $\Delta t_{OP} = -20$ to $+125$ degrees during operation

6.5 SDIO Bus Timing Specifications in DDR50 Mode

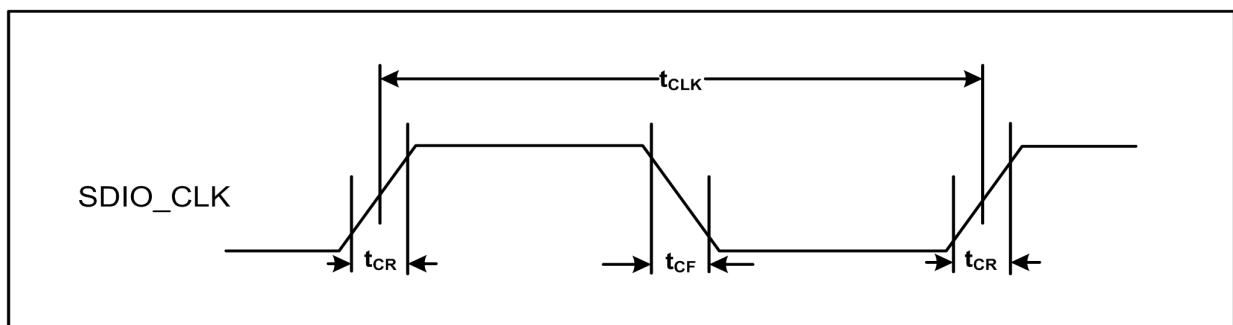

parameter	Symbol	Minimum	Maximum	Unit	Comments
-	t_{CLK}	20	-	ns	DDR50 mode
-	t_{CR}, t_C	-	$0.2 \times t_{CLK}$	ns	$t_{CR}, t_{CF} < 4.00 \text{ ns (max) @ } 50 \text{ MHz, } C_{CARD} = 10 \text{ pF}$
Clock duty	-	45	55	%	-

Data Timing

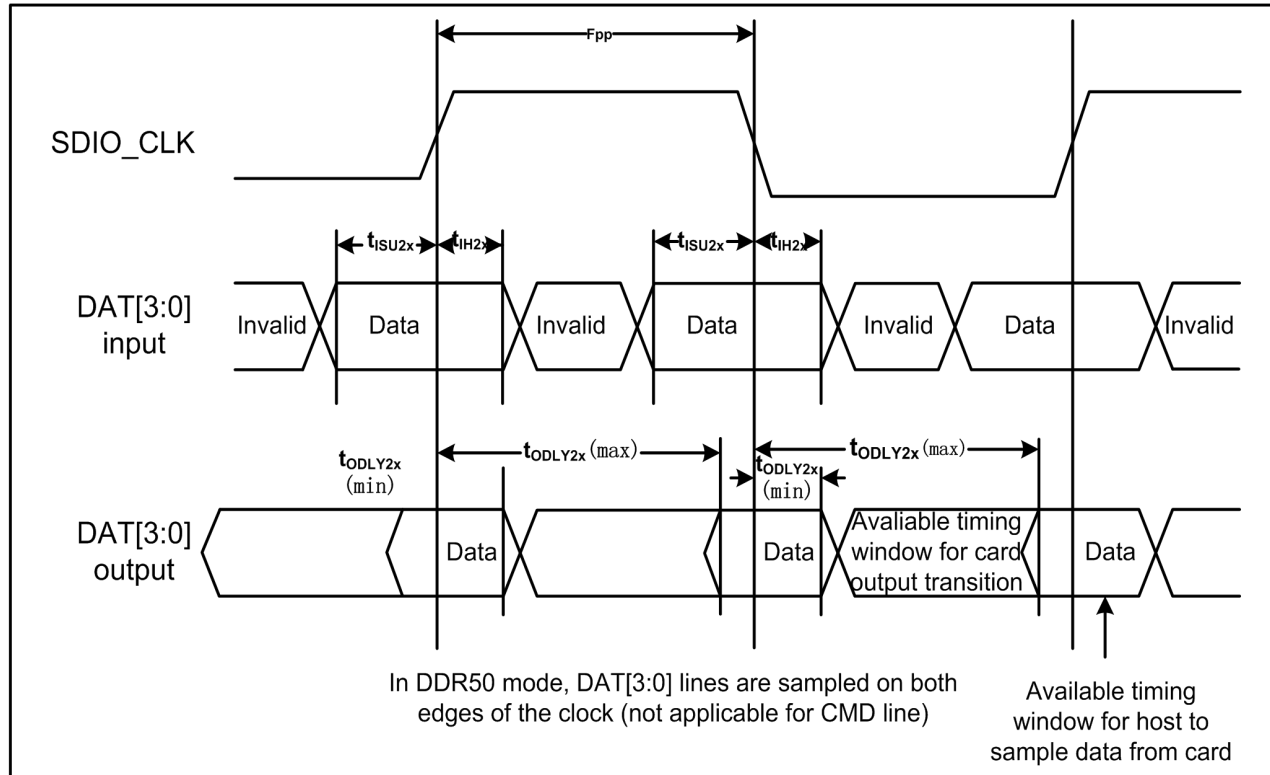

parameter	Symbol	Minimum	Maximum	Unit	Comments
Input CMD					
Input setup time	t_{ISU}	6	-	ns	$C_{CARD} < 10 \text{ pF}$ (1 Card)
Input hold time	t_{IH}	0.8	-	ns	$C_{CARD} < 10 \text{ pF}$ (1 Card)
Output CMD					
Output delay time	t_{ODLY}	-	13.7	ns	$C_{CARD} < 30 \text{ pF}$ (1 Card)
Output hold time	t_{OH}	1.5	-	ns	$C_{CARD} < 15 \text{ pF}$ (1 Card)
Input DAT					
Input setup time	t_{ISU2x}	3	-	ns	$C_{CARD} < 10 \text{ pF}$ (1 Card)
Input hold time	t_{IH2x}	0.8	-	ns	$C_{CARD} < 10 \text{ pF}$ (1 Card)
Output DAT					
Output delay time	t_{ODLY2x}	-	7.85 ^a	ns	$C_{CARD} < 25 \text{ pF}$ (1 Card)
Output hold time	t_{ODLY2x}	1.5	-	ns	$C_{CARD} < 15 \text{ pF}$ (1 Card)

a. SDIO 3.0 specification value is 7.0 ns

7 Reference Design

C11/C12 should be closed to pin34
 C9/C10 should be closed to pin36

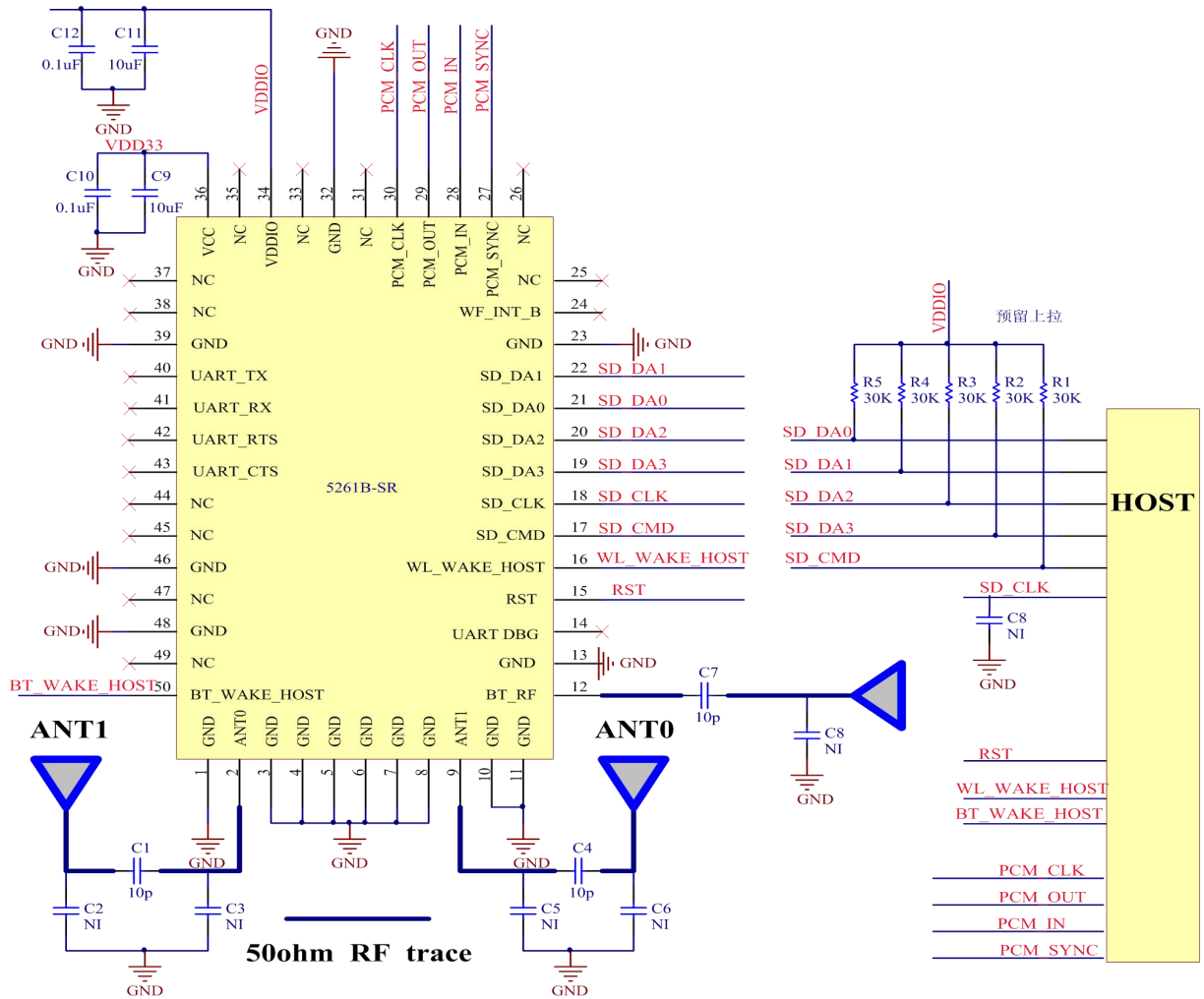

8 Ordering Information

Part No.	Description
FG5261BSRX-00	MT7661RSN, a/b/g/n/ac, WiFi+BT5.0, 2T2R, SDIO, 3 天线
FG5261BSRX-K0	MT7661RSN, a/b/g/n/ac, WiFi+BT5.0, 2T2R, SDIO,3 天线(客供 IC)

9 The Key Material List

Main	Inductor	0805 2.2UH,±20%,1200mA	Microgate,sunlord, cenke, ceaiya
Main	Diplexer	DP1608-A2455DTA2T/LF (ACX)	
Alt.	Diplexer	1608 2.4G/5.8G walsin	
Alt.	Diplexer	1608 2.4G/5.8G Glead	
Main	Crystal	2520 40MHz 10ppm 12pF E2SB40E000900E (鸿星)	
Alt.	Crystal	2520 40MHz 12pF ±10ppm (ECEC)	
Alt.	Crystal	2520 40MHz 12pF ±10ppm (TKD)	
Alt.	Crystal	2520 40MHz 12pF ±10ppm (JWT)	
Main	Chipset	MT7661RSN	MTK
Main	PCB	5261B-SR-V1.0,Green,FR4,4Layer,13X15X0.8mm	XY-PCB,KX-PCB,SL-PCB,sunlord

10 Recommended Reflow Profile

Referred to IPC/JEDEC standard.

Peak Temperature: $\leq 260^{\circ}\text{C}$

Time within 5°C of peak temperature: $\geq 10\text{s}$

Number of Times: ≤ 2 times

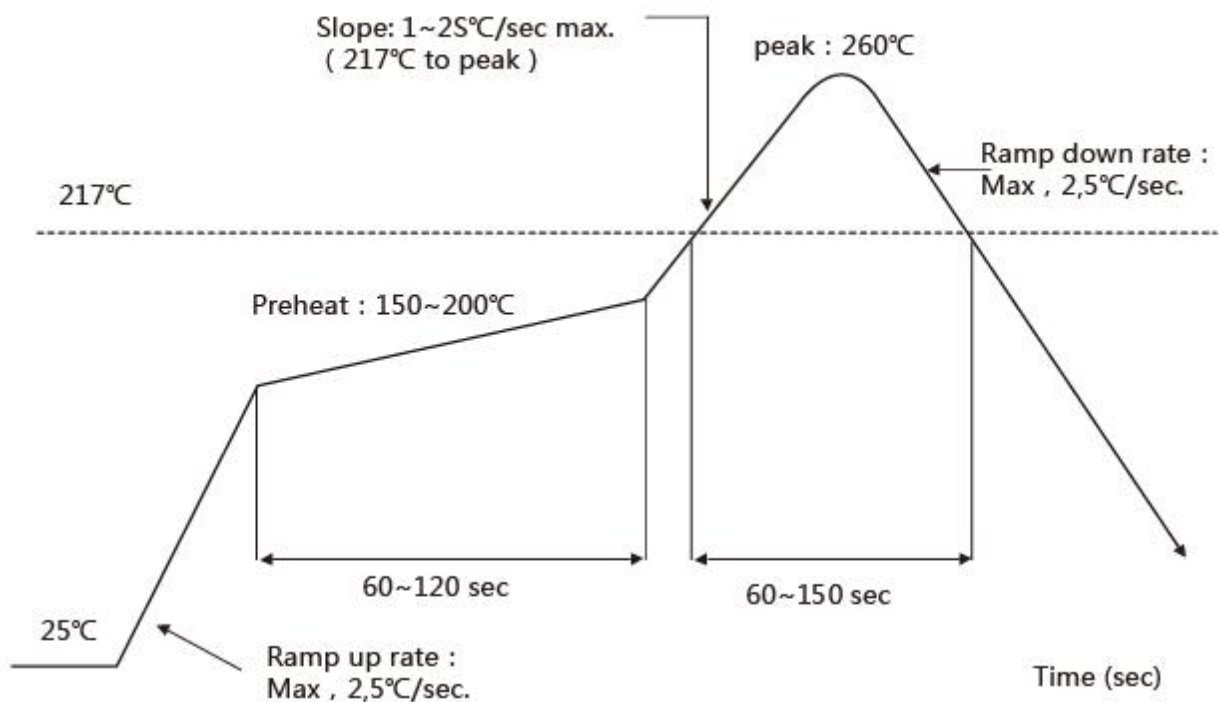

11 Package Information

11.1 Reel

A roll of 1500pcs

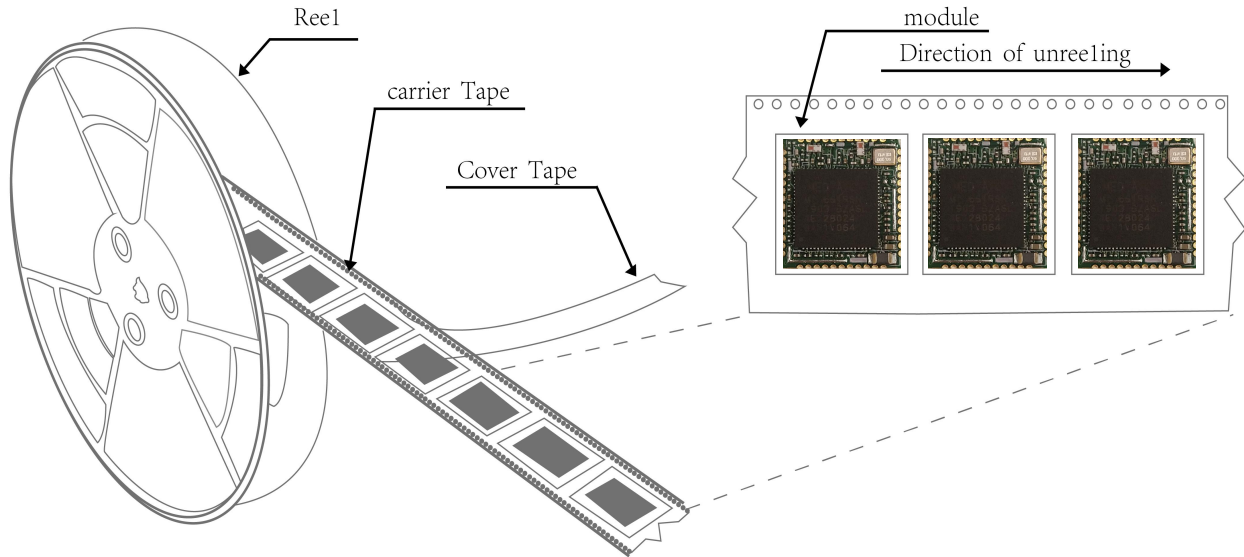

11.2 Carrier Tape Detail

ITEM	W	A0	B0	D	F	E	K0	P0	P2	P	T
DIM	24	13.50	15.40	1.50	11.5	1.75	1.80	4.0	2.0	20.0	0.30
TOLE	+0.3 -0.3	±0.15	±0.15	+0.1 -0.0	+0.1 -0.1	±0.1	±0.10	±0.1	±0.1	±0.1	±0.05

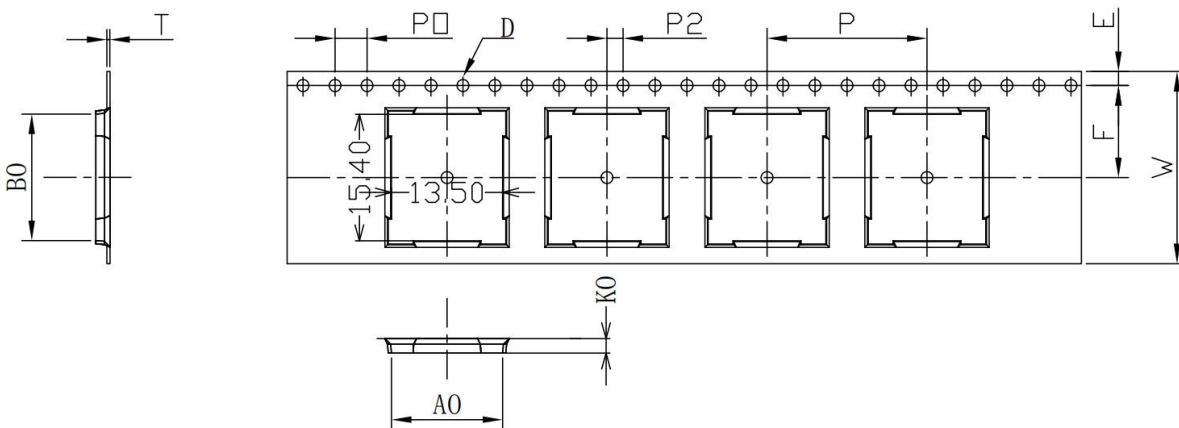

11.3 Packaging Detail

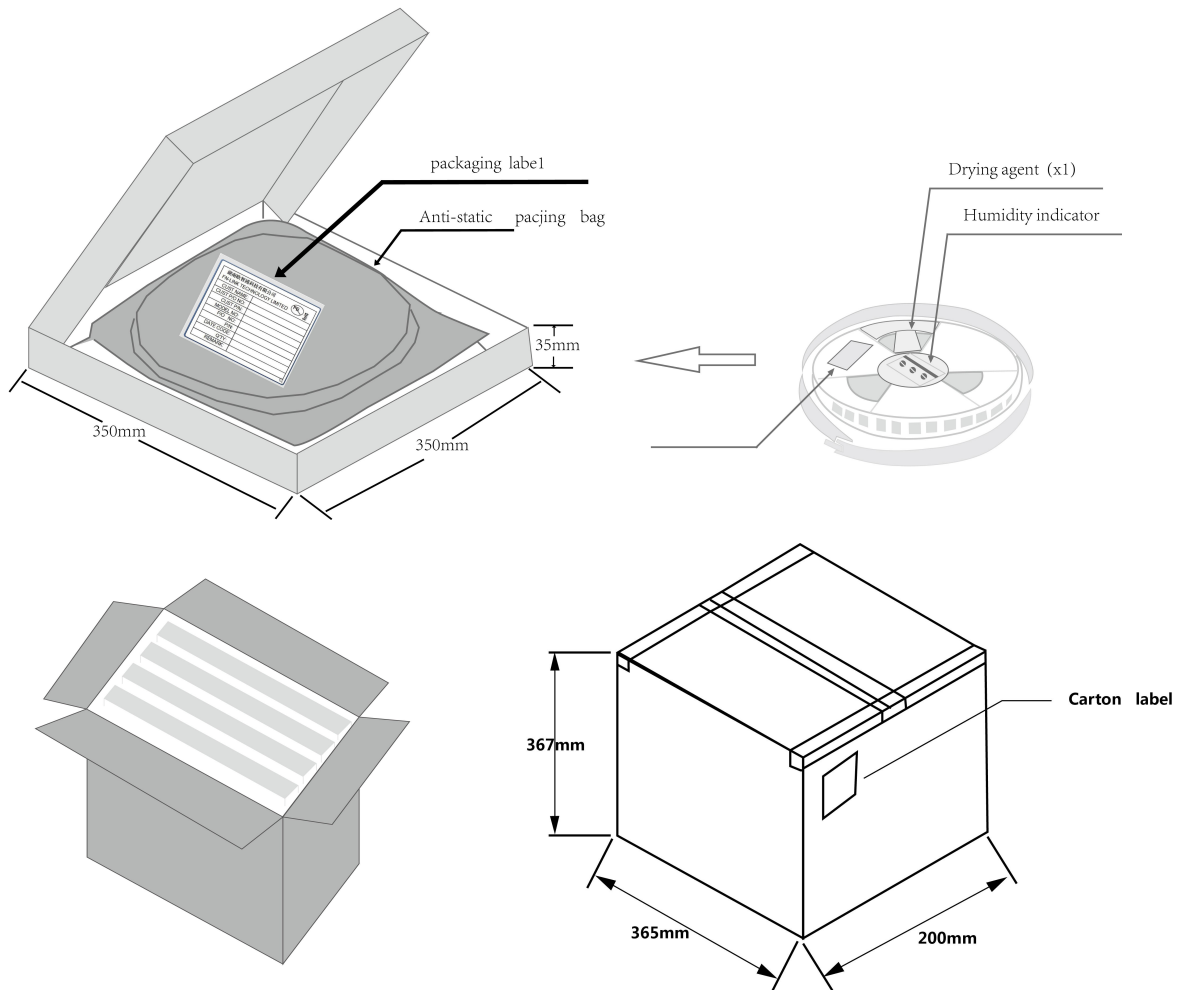

11.4 Moisture sensitivity

The Modules is a Moisture Sensitive Device level 3, in according with standard IPC/JEDEC J-STD-020, take care

all the relatives requirements for using this kind of components.

Moreover, the customer has to take care of the following conditions:

- Calculated shelf life in sealed bag: 12 months at $<40^{\circ}\text{C}$ and $<90\%$ relative humidity (RH)
- Environmental condition during the production: 30°C / 60% RH according to IPC/JEDEC J-STD-033A paragraph 5
- The maximum time between the opening of the sealed bag and the reflow process must be 168 hours if condition
- "IPC/JEDEC J-STD-033A paragraph 5.2" is respected
- Baking is required if conditions b) or c) are not respected
- Baking is required if the humidity indicator inside the bag indicates 10% RH or more